



DURA BIKE RACKS

A DIVISION OF HANNAN SPECIALTIES INC.

Made in the USA

**DIMENSION SHEET FOR
MODEL : CHP-9-IG(SF,SG)**
(Challenger Plus Bike Rack)

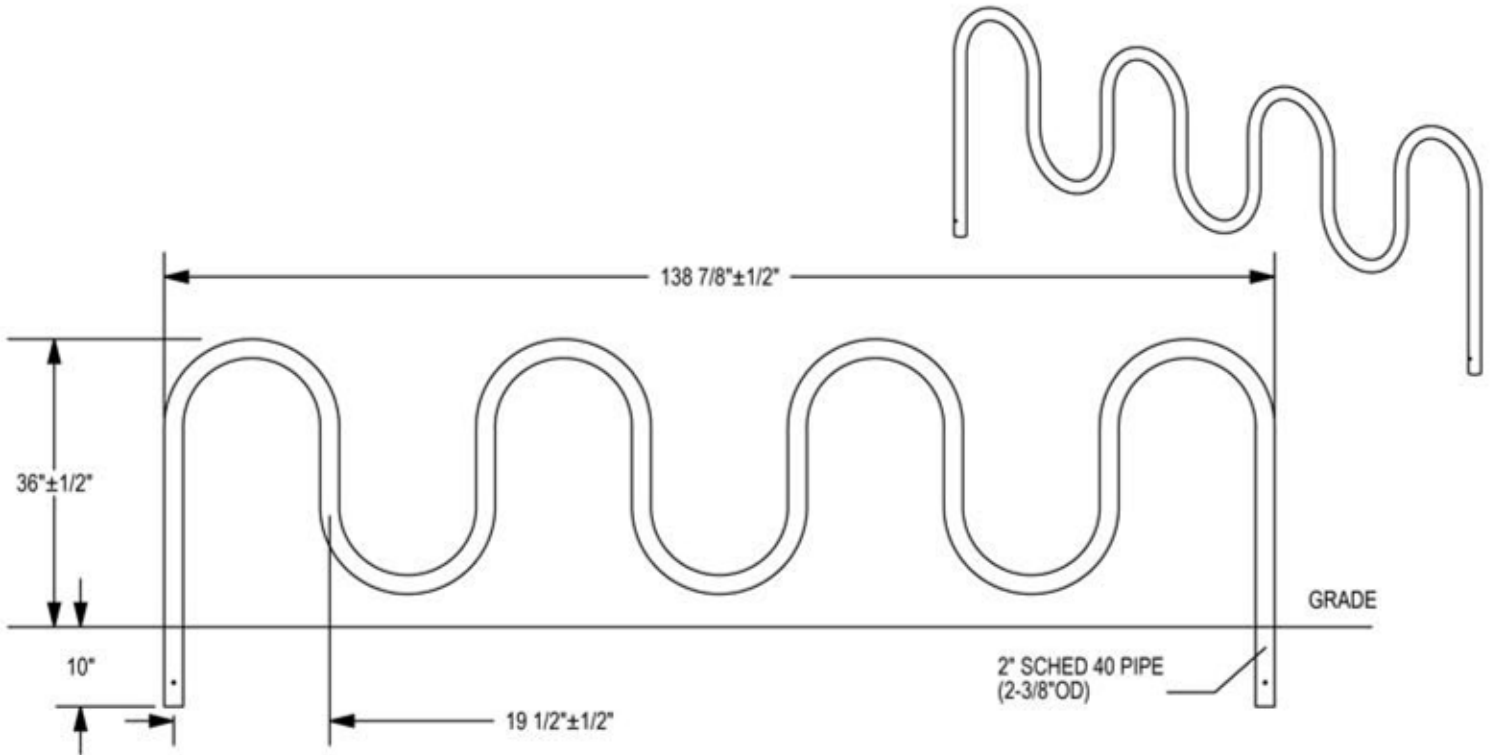

7 LOOP - 9 BIKE CAPACITY

CHECK DESIRED MOUNT

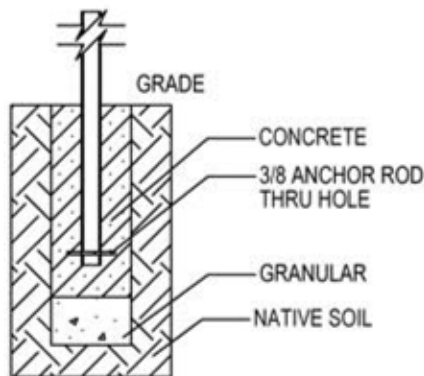

IN GROUND MOUNT (IG)

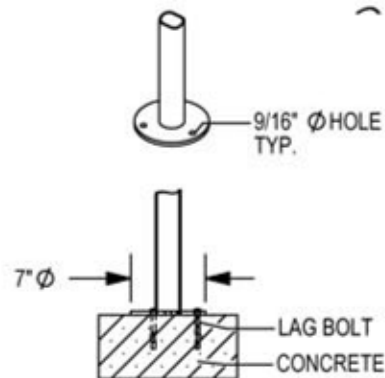

SURFACE FLANGE MOUNT (SF)

SECTION VIEWS

www.durabikelocker.com
4019 LEOS LN. #3 - CARMICHAEL, CA 95608
(916) 488-7026 - (800) 722-BIKE (2453)